





March 7 – 11, 2012
Green Valley Ranch
Las Vegas (Henderson), NV

April 18 – 22, 2012
Omni Severin Indianapolis
Indianapolis, IN

-  Sales Training
-  Service Technician Training
-  Water Treatment Training
-  CWT Exam

AWT Training Seminars

2012

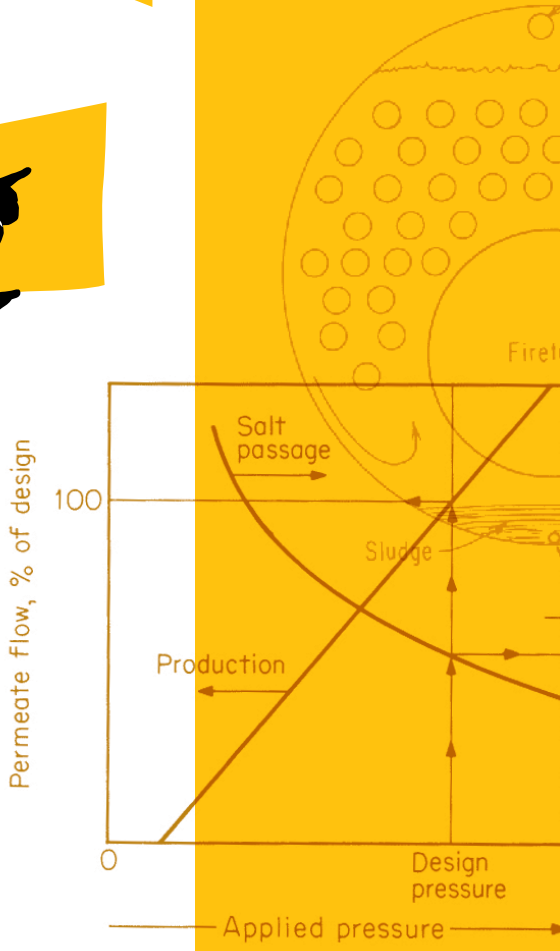
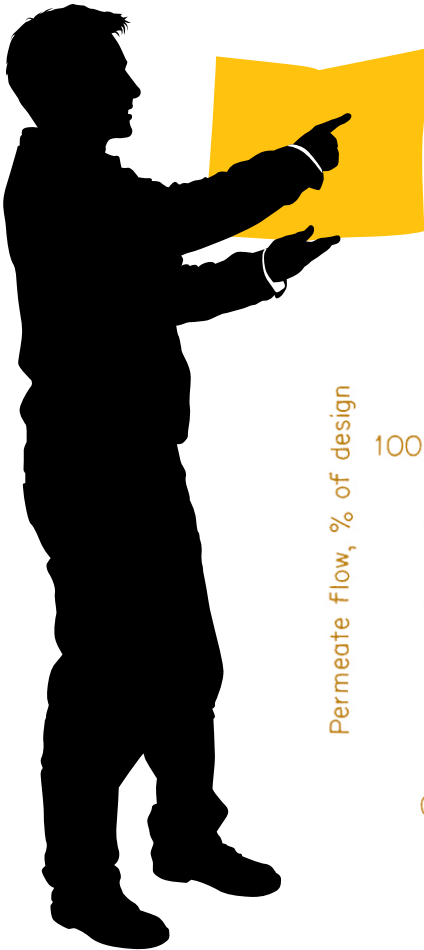

$$HTI = 0.693 \times \frac{\text{capacity} \times (CR - 1)}{Q_c \times \Delta T \times 0.001}$$

“Great speakers and information, and collectively the most intelligent and brilliant minds in the water treatment industry today.”

Invest in Success

The skills learned at the Association of Water Technologies (AWT) training seminars can provide big payoffs in increased productivity, knowledge, and employee and customer loyalty. As a water treatment professional, you can learn about the latest technologies and best practices in the industry to help you meet the growing needs of your customers. Whether you're a novice or veteran, you can supplement your in-house training program by attending these basic and advanced technical sessions.

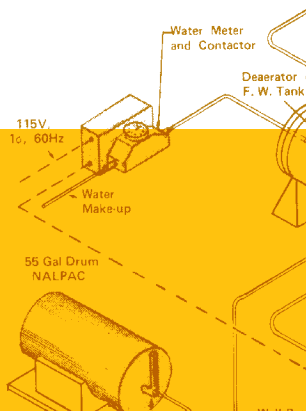
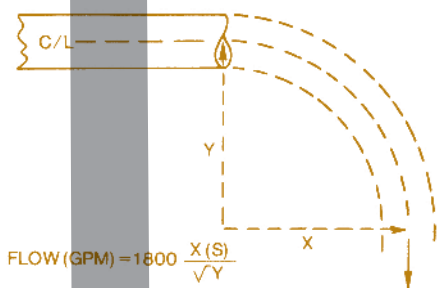

Why You Should Attend

- Learn or renew the technical skills you need to excel in your field
- Learn best practices to better serve your clients
- Increase your productivity and sales
- Enhance your value as an asset to your company
- Boost your confidence with new and renewed knowledge
- Gain credibility with your industry peers



Respected, Expert Faculty

Our speakers represent the very best in the industry, with credentials that are unparalleled. These experienced water treatment veterans have the patience, willingness and desire to share their knowledge in order to equip you with the necessary tools for success. And, they provide this service at no cost to AWT, which allows us to offer quality, reasonably priced training and keep your attendance costs down!

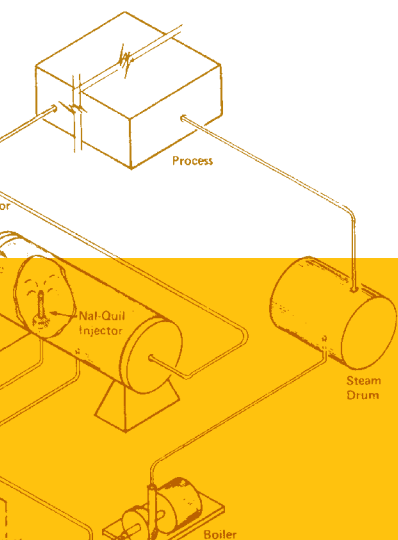

Sales Training

Wednesday, March 7, 2012—Las Vegas (Henderson), NV
 Wednesday, April 18, 2012—Indianapolis, IN

7:30 am – 8:00 am	Registration/Continental Breakfast
8:00 am – 10:00 am	Laying a Foundation Colin Frayne, CWT— <i>Aquassurance, Inc.</i>
10:00 am – 10:15 am	Refreshment Break
10:15 am – 12:15 pm	Exploring the Selling Sequence Colin Frayne, CWT— <i>Aquassurance, Inc.</i>
12:15 pm – 1:15 pm	Lunch
1:15 pm – 3:00 pm	The 7-Step Selling Circle—In Depth! Colin Frayne, CWT— <i>Aquassurance, Inc.</i>
3:00 pm – 3:15 pm	Refreshment Break
3:15 pm – 5:00 pm	Boot Camp Mastery of Selling Colin Frayne, CWT— <i>Aquassurance, Inc.</i>

Key

- Sales Training
- Service Technician Training
- Water Treatment Training
- CWT Exam

Technical Training—Day 1

Thursday, March 8, 2012—Las Vegas (Henderson), NV
 Thursday, April 19, 2012—Indianapolis, IN

	Service Technician Training	Water Treatment Training
7:30 am – 8:00 am	Registration/Continental Breakfast	7:30 am – 8:00 am Registration/Continental Breakfast
8:00 am – 8:05 am	Course Introduction Bruce T. Ketrick, Sr., CWT <i>Guardian CSC</i>	8:00 am – 8:05 am Course Introduction Bruce T. Ketrick, Sr., CWT <i>Guardian CSC</i>
8:05 am – 8:30 am	Opening Comments Chris Golden, CWT <i>Taylor Technologies, Inc.</i>	8:05 am – 10:00 am Regulatory and Safety Issues Jay Farmerie, CWT <i>GLA Water Consultants, Inc.</i>
8:30 am – 9:00 am	A Service Technician's Role—Small Group Discussions	
9:00 am – 9:30 am	A Service Technician's Role—Group Reporting / Discussion	
9:30 am – 10:00 am	Account Service Guidelines: Call Objectives & Procedures Peter Greenlimb, Ph.D., CWT <i>Chemagineering Corporation</i>	
10:00 am – 10:15 am	Refreshment Break	10:00 am – 10:15 am Refreshment Break
10:15 am – 11:15 am	Service Territory Management: Planning, Scheduling and Time Management Bruce T. Ketrick, Sr., CWT <i>Guardian CSC</i>	10:15 am – 12 Noon Emerging Technologies
11:15 am – 12 Noon	Basics: Water Chemistry Peter Greenlimb, Ph.D., CWT <i>Chemagineering Corporation</i>	
12 Noon – 1:00 pm	Lunch	12 Noon – 1:00 pm Lunch
1:00 pm – 3:00 pm	Basics: Water & Cooling Water Chemistry & Stability Indexes Exercise Peter Greenlimb, Ph.D., CWT <i>Chemagineering Corporation</i> Chris Golden, CWT <i>Taylor Technologies, Inc.</i>	1:00 pm – 3:30 pm Water Chemistry Colin Frayne, CWT <i>Aquassurance, Inc.</i>
3:00 pm – 3:15 pm	Refreshment Break	
3:15 pm – 4:30 pm	Cooling Water Scale, Fouling and Corrosion Peter Greenlimb, Ph.D., CWT <i>Chemagineering Corporation</i>	3:30 pm – 3:45 pm Refreshment Break
4:30 pm – 5:00 pm	Cooling Water Exercises Peter Greenlimb, Ph.D., CWT <i>Chemagineering Corporation</i> Chris Golden, CWT <i>Taylor Technologies, Inc.</i>	3:45 pm – 5:30 pm Water Testing Frank Lechrone, III <i>AquaPhoenix Scientific, Inc.</i>
5:00 pm – 7:00 pm	Cooling Water Exercises	5:30 pm – 7:30 pm Advanced Calculations and Optional Tutoring

Technical Training—Day 2

Friday, March 9, 2012—Las Vegas (Henderson), NV
 Friday, April 20, 2012—Indianapolis, IN

Service Technician Training		Water Treatment Training	
7:30 am–8:00 am	Continental Breakfast	7:30 am–8:00 am	Continental Breakfast
8:00 am–8:30 am	Cooling Water Exercises Peter Greenlimb, Ph.D., CWT <i>Chemagineering Corporation</i> Chris Golden, CWT <i>Taylor Technologies, Inc.</i>	8:00 am–10:30 am	Calculations R. Trace Blackmore, CWT, LEED GA <i>Blackmore Enterprises, Inc.</i>
8:30 am–9:30 am	Relationship Management Colin Frayne, CWT <i>Aquassurance, Inc.</i>		
9:30 am–10:00 am	Boiler System Basics Chris Golden, CWT <i>Taylor Technologies, Inc.</i>		
10:00 am–10:15 am	Refreshment Break		
10:15 am–11:15 am	Pretreatment Equipment Basics Chris Golden, CWT <i>Taylor Technologies, Inc.</i>	10:30 am–10:45 am	Refreshment Break
11:15 am–12 Noon	Boiler Feedwater, Boiler Water and Condensate Chris Golden, CWT <i>Taylor Technologies, Inc.</i>	10:45 am–12 Noon	Pretreatment/Filtration Bruce T. Ketrick, Sr., CWT <i>Guardian CSC</i>
12 Noon–1:00 pm	Lunch	12 Noon–1:00 pm	Lunch
1:00 pm–2:00 pm	Boiler Water Treatment Chris Golden, CWT <i>Taylor Technologies, Inc.</i>	1:00 pm–2:00 pm	Pretreatment/Filtration, Continued Bruce T. Ketrick, Sr., CWT <i>Guardian CSC</i>
2:00 pm–3:00 pm	Boiler Water Calculations Chris Golden, CWT <i>Taylor Technologies, Inc.</i>	2:00 pm–3:30 pm	Boiler Water Treatment Bruce T. Ketrick, Sr., CWT <i>Guardian CSC</i>
3:00 pm–3:15 pm	Refreshment Break		
3:15 pm–4:15 pm	Account Service Guidelines: Health & Safety Jay Farmerie, CWT <i>GLA Water Consultants, Inc.</i>	3:30 pm–3:45 pm	Refreshment Break
4:15 pm–5:00 pm	Boiler Water Exercises Peter Greenlimb, Ph.D., CWT <i>Chemagineering Corporation</i> Chris Golden, CWT <i>Taylor Technologies, Inc.</i>	3:45 pm–5:30 pm	Boiler Water Treatment, Continued Bruce T. Ketrick, Sr., CWT <i>Guardian CSC</i>
5:00 pm–7:00 pm	Boiler Water Exercises	5:30 pm–7:00 pm	Advanced Calculations and Optional Tutoring

The illustration shows two silhouetted figures sitting at a desk with a computer monitor and keyboard. To the right is a schematic diagram of a water treatment process. It features a 'Feed' input on the left that splits into two parallel paths, each containing a rectangular component (likely a filter or membrane). These paths then merge and lead to a 'Primary reject' stream. A 'Recycle' stream is shown at the top right, which loops back to the input of the first parallel path. Below the main flow, there are two output streams labeled 'Primary permeate' and 'Secondary permeate'.

Below the diagram, the following equation is presented:

$$H = 693 \times \frac{\text{capacity} \times (CR - 1)}{Q_c \times \Delta T \times 0.001}$$

Technical Training—Day 3

Saturday, March 10, 2012—Las Vegas (Henderson), NV
 Saturday, April 21, 2012—Indianapolis, IN

	Service Technician Training	Water Treatment Training
7:30 am–8:00 am	Continental Breakfast	7:30 am–8:00 am Continental Breakfast
8:00 am–8:30 am	Boiler Water Exercises Peter Greenlimb, Ph.D., CWT <i>Chemagineering Corporation</i> Chris Golden, CWT <i>Taylor Technologies, Inc.</i>	8:00 am–10:00 am Feed and Control Equipment Blaine Nagao, CWT <i>ChemCal, Inc.</i>
8:30 am–10:00 am	Account Service Guidelines: Chemical Feed Equipment Greg Powell <i>Advantage Controls, Inc.</i>	
10:00 am–10:15 am	Refreshment Break	10:00 am–10:15 am Refreshment Break
10:15 am–10:45 am	Account Service Guidelines: Chemical Feed Equipment Demonstration Greg Powell <i>Advantage Controls, Inc.</i>	10:15 am–12 Noon Cooling Water Chemistry, Corrosion and Scale Jim Lukanich, CWT <i>ChemCal, Inc.</i>
10:45 am–11:30 am	Account Service Guidelines: System Sampling and Testing Peter Greenlimb, Ph.D., CWT <i>Chemagineering Corporation</i> Chris Golden, CWT <i>Taylor Technologies, Inc.</i>	
11:30 am–12 Noon	Account Service Guidelines: Service Reporting Procedures Peter Greenlimb, Ph.D., CWT <i>Chemagineering Corporation</i> Chris Golden, CWT <i>Taylor Technologies, Inc.</i>	
12:00 Noon–1:00 pm	Lunch	12 Noon–1:00 pm Lunch
1:00 pm–1:30 pm	Account Service Guidelines: Service Reporting Procedures, Continued Peter Greenlimb, Ph.D., CWT <i>Chemagineering Corporation</i> Chris Golden, CWT <i>Taylor Technologies, Inc.</i>	1:00 pm–3:30 pm Cooling Water Microbiology and Biofilms Jim Lukanich, CWT <i>ChemCal, Inc.</i>
1:30 pm–3:00 pm	Putting It All Together: Practical Applications of Cooling Water and Boiler Water Principles Peter Greenlimb, Ph.D., CWT <i>Chemagineering Corporation</i> Chris Golden, CWT <i>Taylor Technologies, Inc.</i>	
3:00 pm–3:15 pm	Refreshment Break	3:30 pm–3:45 pm Refreshment Break
3:15 pm–4:00 pm	Open Forum, Group Discussion, Q & A	3:45 pm–5:00 pm Cooling Water Microbiology and Biofilms, Continued Jim Lukanich, CWT <i>ChemCal, Inc.</i>
		5:30 pm–7:00 pm Advanced Calculations and Optional Tutoring

CWT Exam

Sunday, March 11, 2012—Las Vegas (Henderson), NV
 Sunday, April 22, 2012—Indianapolis, IN

7:30 am	CWT Exam Sign-In
8:00 am–1:00 pm	CWT Exam

Course Descriptions

Sales Training

Colin Frayne, CWT
Aquassurance, Inc.

Laying a Foundation

This session will begin by addressing why there is a need for professional selling and marketing skills. From there, Colin will share some initial thoughts on selling and explain the selling triangle. Explanation will be given as to why selling gets more complex, and selling and business world definitions will be given.

Exploring the Selling Sequence

Students will be given practical advice in this section, as attendees take a quick look at PowerPoint presentations to prospects. The presentation will cover the background to professional selling, the selling sequence and the economic buyer. Finally, there will be a review of standard selling sequences and the benefits and limitations of those sequences.

The 7-Step Water Treatment Selling Circle—In Depth!

The realities of selling water treatment will be covered in this hands-on session, as well as prospecting, qualification, building trust, the presentation and closing the deal. Colin will also share insight on new client oversight and relationship management.

Boot Camp Mastery of Selling

Learn to enhance your ROI with better prospecting! This session will also cover the sales scorecard and marketing warfare. Tips will be provided on champion closing and the art of persuasion. Advice will be given on how to overcome objections to keep the sale. Finally, there will be discussion about relationship management and effectively using customer reviews.

Service Technician Training

Peter Greenlimb, Ph.D., CWT
Chemagineering Corporation

Chris Golden, CWT
Taylor Technologies, Inc.

Start with the basics! The Service Technician Training Course is a three-day training experience designed as an educational and instructional program for field service representatives and individuals new to the water management industry. The program will be presented in both lecture and workshop formats (Cooling Water and Boiler Water Account Service and Management). The Service Technician course was expanded from its original basic industry overview to include discussion of fundamental account service concepts. Included in the course are segments dealing with common water management terms, cooling water basics and microbiological control, pretreatment methods and equipment, internal boiler water treatment, and health and safety issues.

"I really learned a lot when the presenters used real world scenarios to strengthen their points."

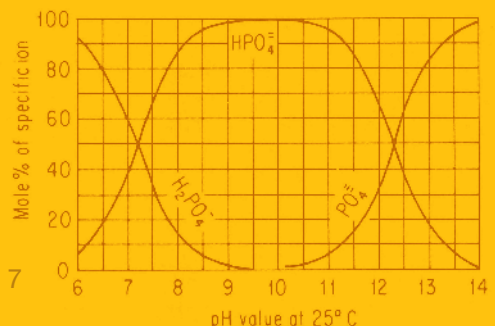

Course Descriptions

Water Treatment Training

Regulatory and Safety Issues

Jay Farmerie, CWT—*GLA Water Consultants, Inc.*

The session provides information on U.S. health, safety, and regulatory requirements that the water treatment professional should be aware of in order to effectively do their job in the field and to make sure they do not cause issues for their clients.

Water Chemistry

Colin Frayne, CWT—*Aquassurance, Inc.*

This session will cover fundamentals of chemistry, required to provide new water treatment personnel with an understanding of the terminology they need to know to perform in the field. Concepts such as pH, alkalinity, hardness, and other ions, and how they relate to deposits and corrosion, are discussed.

Water Testing

Frank Lecrone, III—*AquaPhoenix Scientific, Inc.*

This session is designed to provide the student with a basic understanding of the chemical tests used to monitor cooling water and boiler water treatment programs.

Calculations

R. Trace Blackmore, CWT, LEED GA—*Blackmore Enterprises, Inc.*

Water treatment personnel must understand calculations to develop and maintain a water treatment program. Students will be challenged to use these calculations and the information provided in previous sections to solve real world problems. A calculator is needed for this session.

Pretreatment/Filtration

Bruce T. Ketrick, Sr. CWT—*Guardian CSC*

Students will discuss the equipment that makes up typical low pressure boiler water systems and how they work, including an explanation of water softeners and their function.

Boiler Water Treatment

Bruce T. Ketrick, Sr. CWT—*Guardian CSC*

This section will cover the typical problems encountered in boiler water systems and how they are treated. Students will learn the proper use and application of boiler water products and how to trouble-shoot boiler systems.

Feed and Control Equipment

Blaine Nagao, CWT—*ChemCal, Inc.*

This session provides a primer on the equipment and control systems for boiler and cooling water systems. Students will leave with a conceptual understanding of these systems and exposure to a wide variety of options.

Cooling Water Chemistry, Corrosion and Scale

Jim Lukanich, CWT—*ChemCal, Inc.*

Attendees will receive a comprehensive overview of deposit and corrosion chemistry, including how chemicals are used in the treatment of deposit and corrosion related problems.

Cooling Water Microbiology and Biofilms

Jim Lukanich, CWT—*ChemCal, Inc.*

This discussion covers the wide variety of problems related to the uncontrolled growth of microorganisms in cooling water systems. Biofilm related problems such as fouling, deposits, corrosion and disease and treatment strategies are discussed.

Course Descriptions

Certified Water Technologist (CWT) Exam

The Certified Water Technologist (CWT) designation represents the highest professional credential in the industrial and commercial water treatment field. It provides professional recognition to indicate to the general public, co-workers, employers and others that an individual has achieved a high level of experience, knowledge and education in the industry. The CWT designation assures that water professionals possess a core body of knowledge and have extensive professional experience in all aspects of water treatment.

Continuing Education Credits (CEU's)

Certified Water Technologists (CWTs) need 25 credits within a five-year period to recertify. The Technical Training Seminar qualifies for 15 hours of CEUs for the CWT recertification. The Sales Training Seminar qualifies for 3 hours of CEUs for the CWT recertification. Each CWT will be given a certificate of attendance following the seminar as proof of CEUs earned.

"I have only been in the industry for 2 years, but found the training to be very thorough and useful."

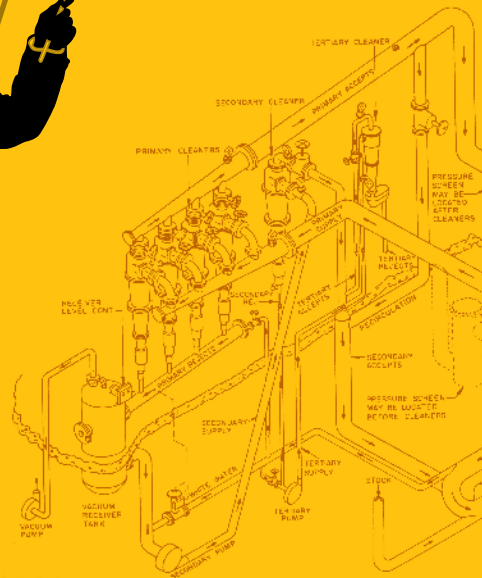
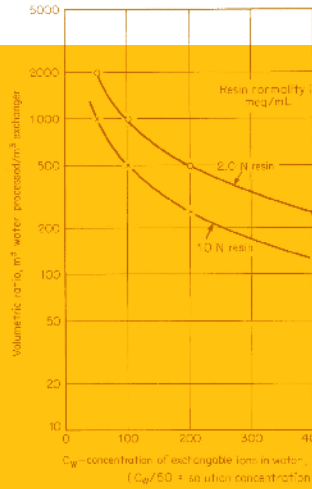

Hotel Accommodations

West

Sales Training

Wednesday, March 7, 2012

Service Technician Training

Water Treatment Training

Thursday, March 8, 2012

– Saturday, March 10, 2012

CWT Exam

Sunday, March 11, 2012

Green Valley Ranch

2300 Paseo Verde Parkway
Las Vegas (Henderson), NV 89052

Phone

(702) 617-7777

Reservation Phone Number

(866) 782-9487

Room Rate

\$110 single/double

Reservation Deadline

Friday, February 3, 2012

Please mention “AWT Training Seminar 2012” in order to obtain the group discounted rate.

Hotel reservations are on a first-come, first-served basis, or until the block has sold out. AWT cannot guarantee the group rate if rooms are still available in the AWT block after Friday, February 3, 2012. Complimentary shuttle service is available to the “Strip”, dropping guests off at the Mandalay Bay Hotel.

Airport

Attendees should fly into McCarran International Airport (LAS) in Las Vegas, Nevada. The resort is located 9 miles, 15 minutes from the airport.

Ground Transportation

Complimentary shuttle service from the airport to the Green Valley Resort is available every two hours beginning at 7:00 am on a first-come, first-served basis. The schedule is available at www.greenvalleyranchresort.com/hotel/.

A variety of shuttle services are available at the airport and are located on the west side of baggage claim outside door exits 7-13.

Taxi

Approximately \$30 one-way

Avis Rent-A-Car

Avis Worldwide Discount number—
J965598. (800) 331-1600

Parking

Complimentary valet and self-parking

East

Sales Training

Wednesday, April 18, 2012

Service Technician Training

Water Treatment Training

Thursday, April 19

– Saturday, April 21, 2012

CWT Exam

Sunday, April 22, 2012

Omni Severin Indianapolis

40 West Jackson Place
Indianapolis, IN 46225

Phone

(317) 634-6664

Reservations Phone Number

(317) 634-6664 or (800) THE-OMNI

Room Rate

\$129 single/double

Reservations Deadline

Monday, April 2, 2012

Please mention “2012 AWT Training Seminar” in order to obtain the group discounted rate.

Hotel reservations are on a first-come, first-served basis, or until the block has sold out. AWT cannot guarantee the group rate if rooms are still available in the AWT block after Monday, April 2, 2012.

Airport

Attendees should fly into Indianapolis, (IND). The Omni Severin Indianapolis Hotel is located 9 miles, 15 minutes from the airport.

Ground Transportation

The Indianapolis Airport’s Ground Transportation Center (GTC) is located on Level 1 of the parking garage. The GTC is a one-stop shop for rental cars, taxi and shuttle service, and public transportation via IndyGo.

Taxi

Approximately \$35 one-way

Avis Rent-A-Car

Avis Worldwide Discount number—
J965598. (800) 331-1600

Parking

\$27 valet overnight

Registration Form

Special Volume Discount for AWT Members Only!

Register more than one individual from your company at the applicable registration rate and receive a \$50 discount on subsequent registrants from your company. This makes it more affordable to send additional members of your company. *Discounts do not apply to Sales Training.*

Please complete one registration form for each attendee.

Please check one: Member Non-Member

First Name MI Last Name Suffix (CWT, Ph.D.)

Badge Name

Company

Title

Company Address

City

State

Zip

Country

Telephone

Fax

Email address (*Registration confirmation and meeting notices will be sent to this e-mail address.*)

In Case of Emergency: Contact Name and Telephone

West Las Vegas, Nevada

East Indianapolis, Indiana

		Sales Training	Service Technician	Water Treatment Training	CWT Exam
Early Registration By 1/13/12 Las Vegas By 3/2/12 Indianapolis	Member 1 st Attendee	<input type="checkbox"/> \$345	<input type="checkbox"/> \$470	<input type="checkbox"/> \$470	<input type="checkbox"/> \$385 Registration Due 2/17/12
	Member Add'l Attendee		<input type="checkbox"/> \$420	<input type="checkbox"/> \$420	
	Non-member Attendee		<input type="checkbox"/> \$655	<input type="checkbox"/> \$655	
Regular Registration After 1/13/12 Las Vegas After 3/2/12 Indianapolis	Member 1 st Attendee	<input type="checkbox"/> \$345	<input type="checkbox"/> \$520	<input type="checkbox"/> \$520	<input type="checkbox"/> \$485 Registration Due 3/30/12
	Member Add'l Attendee		<input type="checkbox"/> \$470	<input type="checkbox"/> \$470	
	Non-member Attendee		<input type="checkbox"/> \$705	<input type="checkbox"/> \$705	

Payment **Total Payment** \$ _____

Check enclosed (made payable to "AWT")—Check # _____

Credit Card: Visa MasterCard American Express

Name as it appears on card

Card Number

Expiration Date

Security Code

Signature

Payment Options

Fax: AWT (301) 990-9771

Mail: Association of Water Technologies
 9707 Key West Avenue, Suite 100
 Rockville, MD 20850

Cancellation Policy

All cancellations must be in writing two weeks prior to the seminar and are subject to a \$50 processing fee.

Questions?

Angela Pike—apike@awt.org



9707 Key West Avenue, Suite 100
Rockville, MD 20850
(240) 404-6478

PRSR T STD
US POSTAGE
PAID
PERMIT NO. 1
SUB MD 208

AWT Training Seminars

March 7 – 11, 2012
Green Valley Ranch
Las Vegas (Henderson), NV

April 18 – 22, 2012
Omni Severin Indianapolis
Indianapolis, IN

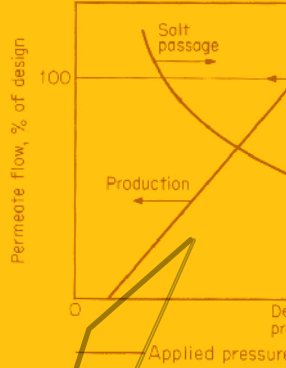

2012